

## 300CPU HOLDER INSTALLATION INSTRUCTIONS

**STEP 2:** Place CPU on its side and center (E) CPU Bottom Support under CPU.

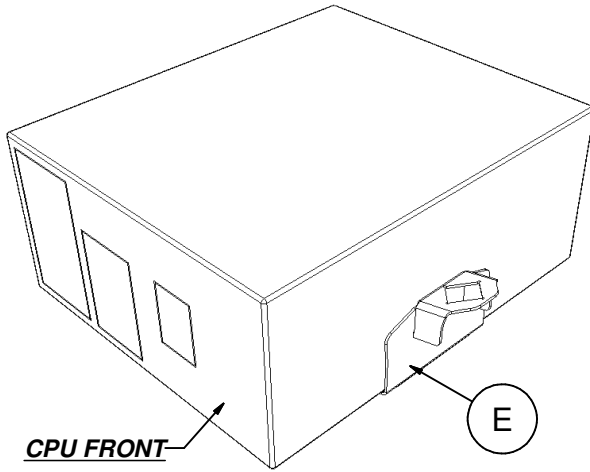

**STEP 3:** Place (C) & (D) through (E) CPU Bottom Support and centered on CPU.

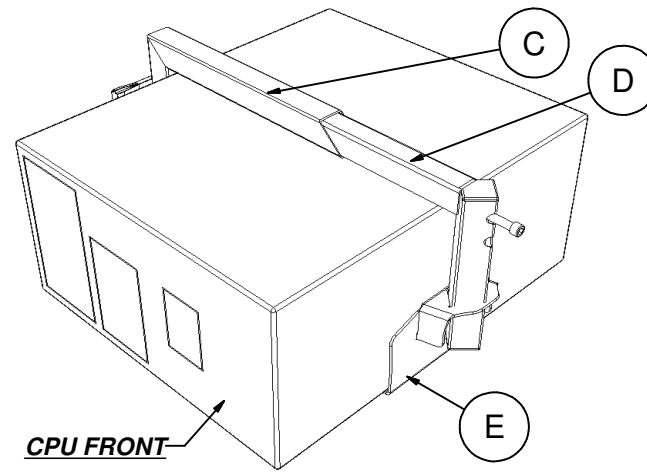

**STEP 4:** Compress the holder with (G) 1/4" Short Arm Hex Key. Tighten until CPU is firmly in place. (NOTE: DO NOT OVER TIGHTEN)

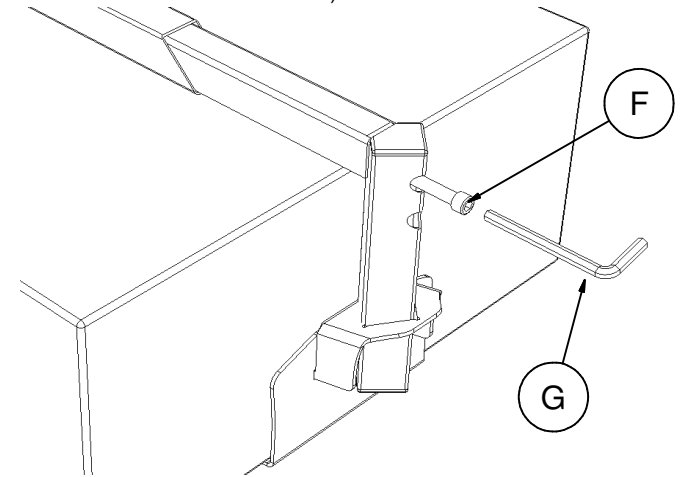

**STEP 5:** Slide the 300CPU (Holder) into the grooves of the (A) Track.

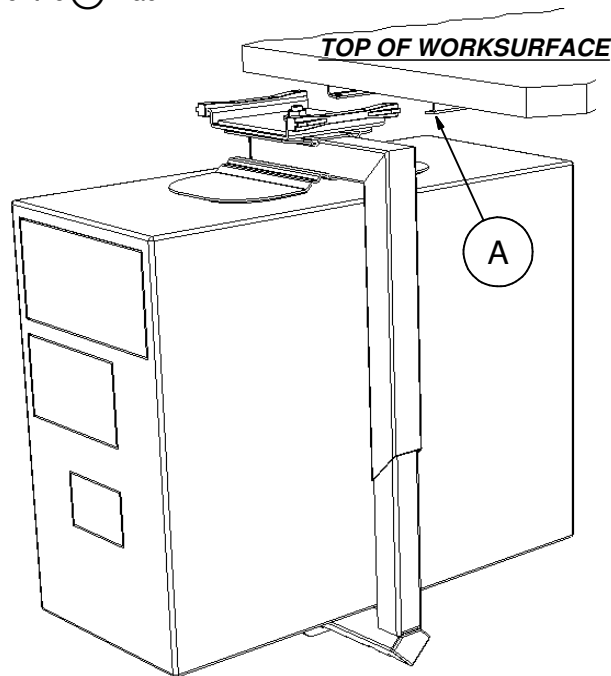

**STEP 6:** Fasten the (H) Track Stop into place with two (J) fasteners or (L) fasteners going through the Track Stop and into the bottom of the work surface.

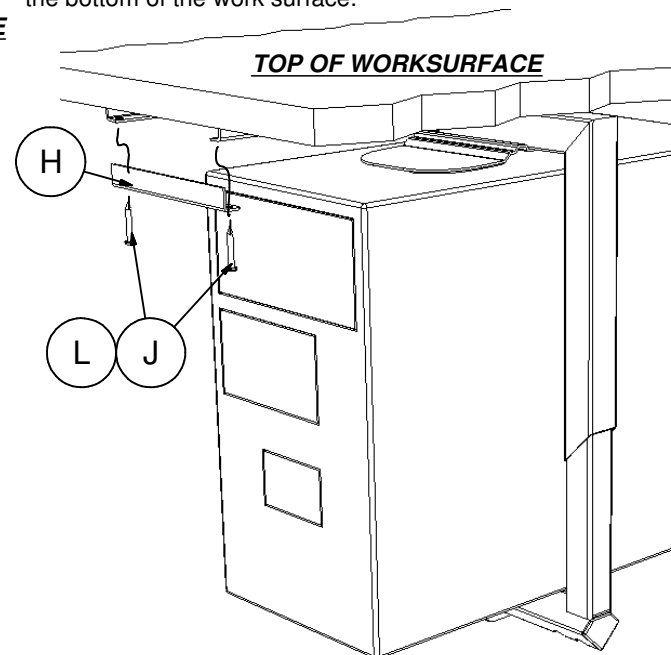

**STEP 7:** Installation is finished. The system is ready to operate.

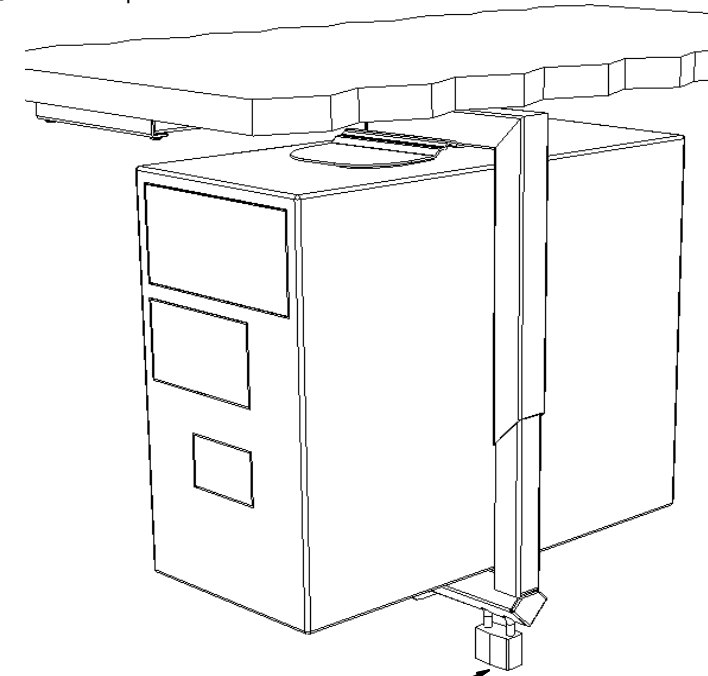

For questions or concerns, please call K & A Manufacturing, Inc. 1-800-298-4351 available Monday-Friday 8:00 AM to 5:00 PM (Central Time)

[www.rightangleproducts.com](http://www.rightangleproducts.com)

02/20/2005